

A POCKET BOOK ON THE USE OF

MEGGER

INSULATION AND CONTINUITY

TESTERS



A POCKET BOOK ON THE USE OF

MEGGER

INSULATION AND CONTINUITY

TESTERS



MEGGER

Trade Mark

**POCKET BOOK
ON INSULATION
AND CONTINUITY
TESTERS**

**HOW TO MAKE INSULATION TESTS
WITH NOTES ON SIMPLE CONTINUITY
TESTS**

Published by

EVERSHED & VIGNOLES LIMITED

ACTON LANE WORKS, CHISWICK, LONDON, W.4

Telegrams & Cables: Megger, London, Telex 22583. Telephone: Chiswick 3670

PUBLICATION NO. 200/7

DECEMBER 1960

CONTENTS

FOREWORD	-	-	-	-	-	-	-	3
WHAT IS AN INSULATOR	-	-	-	-	-	-	-	5
TESTING ELECTRICAL APPLIANCES	-	-	-	-	-	-	-	7
TESTING MOTORS AND GENERATORS	-	-	-	-	-	-	-	11
TESTING HOUSE WIRING	-	-	-	-	-	-	-	17
Insulation Tests	-	-	-	-	-	-	-	21
Continuity Tests	-	-	-	-	-	-	-	29
MEGGER TESTERS								
For insulation Tests only	-	-	-	-	-	-	-	32
For Insulation and Continuity Tests	-	-	-	-	-	-	-	34
For Continuity Tests only	-	-	-	-	-	-	-	35
Principle of operation	-	-	-	-	-	-	-	37
Effect of capacitance	-	-	-	-	-	-	-	38
How to use Megger Testers	-	-	-	-	-	-	-	38
How to record results	-	-	-	-	-	-	-	39

FOREWORD

The use of electrical apparatus and machinery in every sphere of industrial and domestic life makes their safe and continuous operation a matter of vital importance.

Breakdowns mean loss of output and inconvenience, and may cause injury to individuals. The avoidance of such breakdowns, therefore, interests everyone using electricity.

The safety of electrical installations and apparatus depends chiefly on the condition of the insulation and this pocket book explains how this condition can be ascertained by simple tests.

Systematic testing of insulation, which can be carried out with the help of a Megger Insulation Tester, shows whether this insulation is healthy and helps those responsible to maintain it in a satisfactory condition and so avoid interruptions or breakdowns.

The pocket book also gives simple instructions for carrying out continuity tests to ensure that apparatus is properly bonded to earth. The results of all tests should be recorded in a log book. This permanent record is valuable to the maintenance engineer, for it enables him to prove that the plant under his charge is being maintained in a safe condition, or to indicate if repairs are necessary.

WHAT IS AN INSULATOR

In every electrical installation or piece of apparatus, "conductors" and "insulators" are used, the conductor to provide the path to carry the current of electricity, and the insulator to prevent the current leaking from that path.

The value of insulation is expressed in terms of its electrical resistance, the practical unit being the megohm (1 million ohms).

The insulation resistance of different materials varies, and the resistance of any given material will alter according to a number of factors the chief of which, probably, is the degree to which it absorbs moisture. This absorption of moisture lowers the resistance of the material in question, while an accumulation of dirt upon the surface of the material, though it does not theoretically alter the insulation resistance of the material itself, does in effect do so, since it provides a conducting path through the dirt along the surface of the material.

The effect of moisture on insulating material is well shown in the table in Figure 2.

The safety of electrical installations and apparatus depends on the condition of the insulation, which should retain the electricity in the path provided, and it is very desirable, therefore, that the condition of this insulation should be ascertained from time to time, to make sure that it is not deteriorating through the accumulation of dirt, damp, or in any other way.

This resistance can be measured very simply by means of a Megger Insulation Testing Set which indicates directly on a scale the insulation resistance of the apparatus or installation under test.

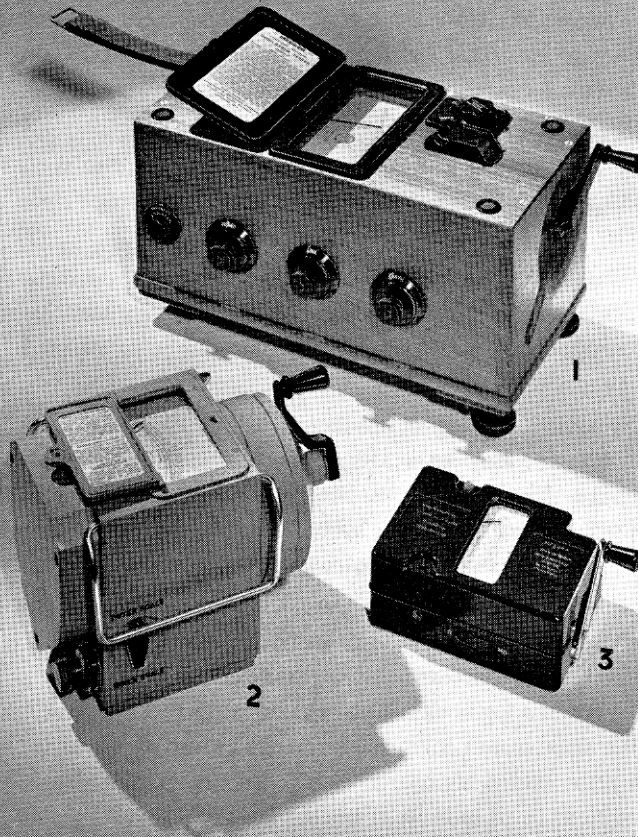

Figure 1 (opposite)

The three series of Megger Insulation Testers.

Series 1

Series 2

Series 3

Time	Insulation Resistance
On placing in drier ..	1000 ohms.
After $\frac{1}{2}$ hour	1.1 megohms.
„ 1 „	6.0 „
„ $1\frac{1}{2}$ „	15.0 „
„ 2 „	26.0 „
„ 3 „	36.0 „
„ 4 „	40.0 „

Figure 2

Tests illustrating the variation in insulation resistance, due to the presence of moisture

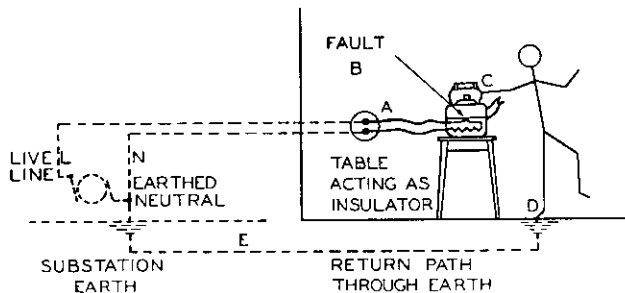

Figure 3

Diagram showing how a man may receive a shock. The heater element being in contact with the kettle at B, the man completes the circuit L A B C D E N

TESTING ELECTRICAL APPLIANCES

A great many portable appliances are connected to the electric supply circuit by means of "adaptors" in lamp-holders, or by means of plugs and wall sockets. Electric irons, toasters, hair dryers and bowl fires are some of the smaller apparatus used in this way.

Under certain conditions a shock can be obtained by touching the casing of a piece of apparatus in which the insulation is defective; this will be understood from Figure 3, where, owing to a fault, the body of the kettle is alive and a return circuit is available through the man's body to the earth connection at the works of the Supply Undertaking.

It should be said at once that electrical apparatus and switches should not be placed in such positions that they can be touched by a person standing on a wet floor unless the metal casings of the apparatus are adequately earthed in accordance with I.E.E. Regulation No. 401,* otherwise a very severe shock may be obtained should a fault develop.

Apart from the risk of shock, the insulation of the apparatus should be maintained in good condition or the apparatus will eventually cease to function.

In hospitals, institutions, or anywhere where there is a large amount of apparatus in use, each piece should be identified by a reference number and regular tests of the insulation resistance should be made at least monthly and recorded in a log-book or register. Such a log-book can, as mentioned on page 39, be obtained free of charge from the publishers of this book.

A record kept in this manner is extremely useful as a guide and, by indicating that some weakness is developing, will enable electrical breakdowns to be avoided. In fact, the purpose of the Megger Insulation Tester is not only to show where a fault exists, but to help to anticipate trouble, and to find where it is necessary to apply that "stitch in time which saves nine."

*I.E.E. Regulations for the Electrical Equipment of Buildings (Thirteenth Edition).

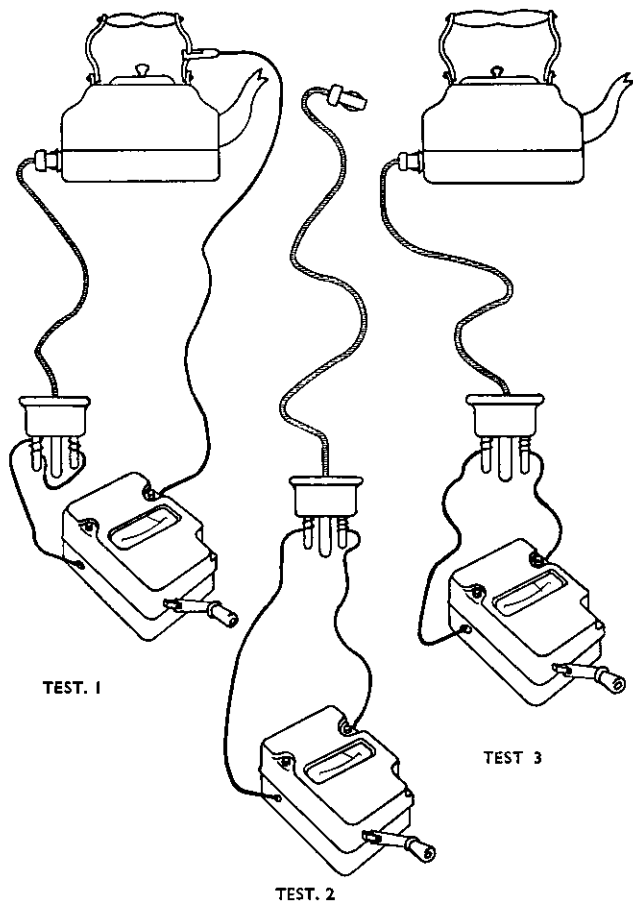

Figure 4 Tests on an electric kettle

How to make tests on appliances

To ensure safety, and to make certain that the apparatus is in a satisfactory working condition, the following three tests should be made with a Megger Insulation Tester (see Page 32).

Test 1. To see if the electrical element has made accidental contact with the frame.

Connect one lead of the testing set to the frame and the other lead to the two conductors (Figure 4).

Turn the instrument handle at 160 r.p.m. when the reading should be several megohms.

Test 2. To see if the insulation of the flexible is sound.

Disconnect the latter at both ends and connect one lead of the testing set to each conductor.

Turn the handle at 160 r.p.m. when the reading should be several megohms.

*Test 3. To see if there is a complete circuit.**

Replace the flexible and test between each conductor turning the handle very slowly, when the reading should be zero. If a zero reading is not obtained, remove the flexible and test between the terminals of the apparatus, to see if the break is in the apparatus or in the flexible.

The actual value of the insulation resistance, as measured in tests 1 and 2, which may be considered satisfactory varies according to the size of the apparatus or installation under test. Such portable apparatus as we are considering at the moment, if it is in good condition, will usually have a resistance of several megohms. It will be safe to use if the resistance is at least one megohm, but the apparatus in such case should be tested at short intervals to see if a fault is developing. If the test gives a figure which is much below one megohm the apparatus should not be used until the fault has been cleared, which may be effected in many cases by cleaning the terminals, or removing and refitting the flexible connecting wire.

**This test is best carried out with a Megger Insulation and Continuity Tester or with a Megger Circuit Tester as both these instruments have a low range enabling the actual resistance of the apparatus to be measured.*

Generator No. 1. 40 KW. 110 volts

Date	Insulation Resistance. Megohms.	Weather condition	Time of Test Temperature of Machine
Feb. 25	15	Fine and bright	Machine hot
27	10	—	Monday morning Machine cold
Mar. 10	50	Cold and dry	Machine hot
12	30	Very cold and dry	Monday morning Machine cold

Generator No. 2. 50 KW. 110 volts

Feb. 25	25	Fine and bright	Machine hot
27	15	Fine and bright	Monday morning Machine cold
29	50	Dull and dry	Hot after 12 hours at 28 K/Ws.
Mar. 1	12	Rainy	After standing 12 hours
10	100	Cold and dry	Machine hot
12	50	Very cold and dry	Monday morning Machine cold

Generator No. 3. 135 KW. 460 volts
New machine being erected

Feb. 24	20	—	Armature only
24	25	—	Field only
Mar. 5	4	—	Complete machine on completion of erection
8	2.5	Fine	Machine hot
9	30	Fine	Machine cold after standing all day
12	75	Very cold and dry	Machine cold
23	20	Fine	Machine hot Test after running all day

Figure 5

INSULATION TESTS ON POWER HOUSE GENERATORS
with 500 volts Constant Pressure Megger Insulation Tester

TESTING MOTORS AND GENERATORS

Faults on electrical machinery must be due to one of two causes. One is the absence of continuity in the conductor which is supposed to be carrying the current. The other is an absence, or partial absence, of insulation. The latter is by far the more common and the more dangerous of the two faults. A burnt out armature, for instance, is usually due to insulation failure.

It is of the utmost importance, therefore, to make regular tests of the insulation resistance of all machinery so as to detect incipient faults. The result of such tests should be entered in a log-book. Entries from a typical log book are shown in Figure 5 and it should be noted that, against each entry, a reference is made to the state of the weather and to whether a machine has been tested when hot or cold, as these conditions may influence the value of the insulation resistance.

Effect of damp weather.

A drop in insulation resistance may often be accounted for by damp weather. An examination, for instance, of the log of Generator No. 2 (Figure 5) reveals that during the 12 hours from February 29th to March 1st the insulation resistance fell from 50 to 12 megohms. It will be noted, however, that the weather conditions deteriorated during this period. That this drop in insulation resistance was due to the change in atmospheric conditions and not to an incipient fault was confirmed by the subsequent test on March 10th, when the weather was again dry and the resistance had risen to 100 megohms.

Effect of temperature.

As regards the effect of temperature it should be noted that the insulation resistance of motors and generators is generally lower when they are hot than when they are cold as the insulating varnishes used in the building of the machines have a lower resistance when hot than when cold.

When to make tests.

It is a good plan, therefore, to make the test of a machine as soon after it has been shut down as possible, when the insulation resistance is likely to be lowest. If, after the motor has just been shut down, the insulation resistance is found to be satisfactory, it may be assumed that it will be better at any other time, provided that the machine does not stand idle for long in a humid atmosphere.

If machines are regularly and consistently tested, if these various relevant points are noted in the diary or log, and if these tests are taken whether the machine is behaving well or not, then the work of diagnosing any trouble when it does arise is much simplified. Further, the likelihood of any trouble developing to such an extent that breakdown occurs is remote.

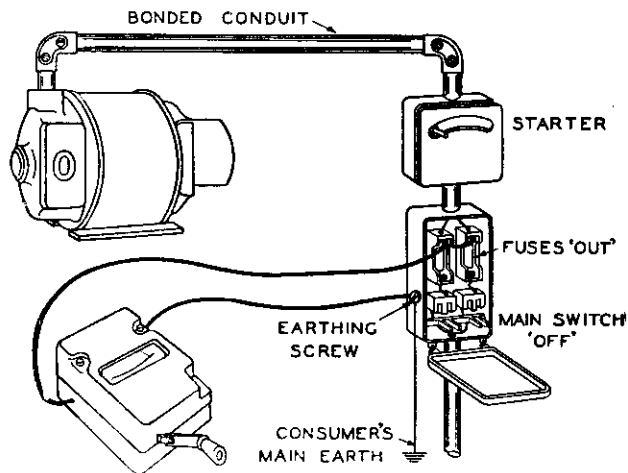

Figure 6

Test to frame or earth on motor and switchgear

Insulation values.

British Standards Specification No. 2613 (which supersedes the former Standard Specification Nos. 168 and 169) states that where requested "Test Certificates shall record the insulation resistance and the temperature at which it was measured."

When a test is made on a new machine, this figure should be obtained at the end of a run at full load when the machine is hot and the insulation resistance is likely to be at the lowest value.

It should be noted that the insulation resistance of a machine which is in good order and has been in use for a substantial period should be higher than the original value.

British Standards Specification No. 170 for Fractional Horse-power Generators and Motors states that the insulation resistance shall not be less than 1 megohm when testing at 500 volts.

In general, a resistance of 1 megohm would be considered satisfactory, but regular tests should be made, as a comparison of the readings obtained will give more information than the absolute value of the insulation resistance.

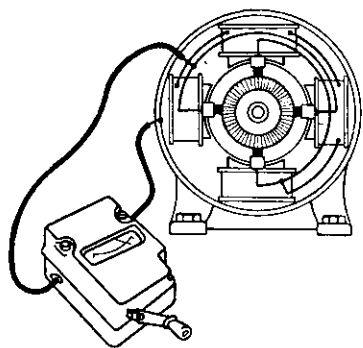

Figure 7
Test on motor only
to frame or earth

BRUSHES
LIFTED OFF
COMMUTATOR

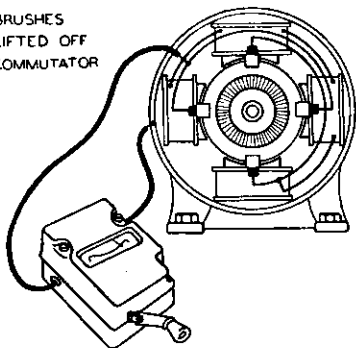

Figure 8
Test on field windings
and brush gear
(armature excluded)

BRUSHES
LIFTED OFF
COMMUTATOR.

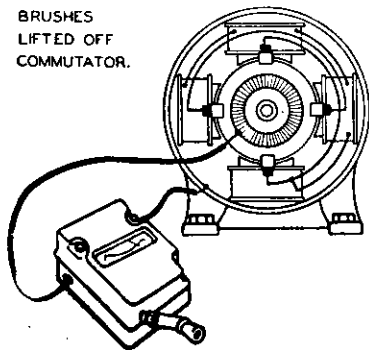

Figure 9
Test on armature only

Making routine tests on motors and generators

(a) D.C. motors and generators

Disconnect the supply of electricity from the motor circuit by opening the main switch and withdrawing the main fuses.

Join together *both* terminals on the motor side of the double pole main switch (Figure 6) and connect these to one terminal of the Megger Insulation Tester.

Connect the other terminal of the Megger Tester to earth, using the frame of the motor or switch.* Turn the instrument handle at 160 r.p.m. and take a reading.

If the insulation resistance between the terminals and the frames is found to be unsatisfactory, it must be ascertained whether the defect is in the starter, in the motor, or in the cables connecting the starter to the motor.

To do this, disconnect the cables at the motor, and repeat the test. If after this disconnection the defect is no longer apparent, then it is evident that the fault does not lie in the starter and cables but in the motor.

Repeat the test on the motor only.

1. With the armature and field windings all connected together (Figure 7);
2. With the brushes lifted from contact with the commutator (Figure 8);
3. On the armature only, between the commutator and frame, the brushes being lifted (Figure 9).

From these tests it can be deduced whether the defect is in the field coils and brush gear, in the armature or in both.

If it is not in the armature, separate out sections of the field windings and components and test individually until the defect is located.

*The metal frames of all the electrical apparatus in the circuit should be permanently connected together and earthed to a water pipe or other good earth. This is essential to ensure that the protective fuses will operate in the event of an earth occurring on the circuit. The efficacy of the earth-continuity conductor may be tested with a Megger Insulation and Continuity Tester (see page 29).

Similarly, if the defect was originally traced to the starter, separate out the various coils such as resistance coils, no-volt release coil and overload coil and test these separately.

In the above description a simple rheostat starter has been taken to illustrate the principles of fault location. The exact procedure will vary with the type of starter. Thus with a contactor operated starter which, in the "off" position, disconnects *all* the lines to the motor, it is necessary to make tests to earth on both the incoming and outgoing terminals of the starter.

It is sometimes found that the insulation resistance is low all round without a definite fault on any section. This can usually be remedied by careful cleaning of the machine, for, when electrical machinery has been in service some time, it is liable to become coated in places with metallic or other conducting dust—in particular a mixture of metallic and carbon dust, often mixed with oil, from commutators or slip rings. Such deposits form leakage paths.

(b) *A.C. motors and generators*

These should be tested in a similar manner to D.C. machines with contactor operated starters, isolating the various circuits until the defect is located.

TESTING HOUSE WIRING

Electricity Supply Regulations 1937

In the above regulations the Electricity Commissioners prescribe in effect (Section 26) that the Electricity Supply Undertakings shall not permanently connect an installation unless they are satisfied that the connection would not cause a leakage exceeding one ten-thousandth part of the maximum current to the installation.

Now this regulation pre-supposes that some form of test be carried out, and whilst no specific tests are mentioned it is usual in practice to measure the insulation resistance of an installation prior to connecting it up.

Further, in Section 27 of these regulations it is stipulated that the Supply Undertakings shall not be compelled to give a supply of energy to any consumer unless they are satisfied that all conductors and apparatus are constructed, installed and protected so as to prevent danger.

The precise nature of the requirements are not specifically mentioned except in so far as this regulation is qualified by the statement that :

"Any consumer's installation which complies with the provisions of the Institution of Electrical Engineers Regulations shall be deemed to fulfil the requirements of this regulation."

Now, according to the I.E.E. Regulations, it is necessary to carry out the following tests to make sure that an installation is safe :

1. Insulation tests (Regulations 501-503)*
 - (a) Between each conductor and earth;
 - (b) Between the conductors themselves.
2. Continuity tests (Regulations 219A, 401-410).

To ensure that the conduit or lead sheathing is electrically continuous throughout and connected to earth.

3. Polarity of switches (Regulation 504).

To ensure that all single pole switches are on the live side of the apparatus they control.

*I.E.E. Regulations for the Electrical Equipment of Buildings (Thirteenth Edition).

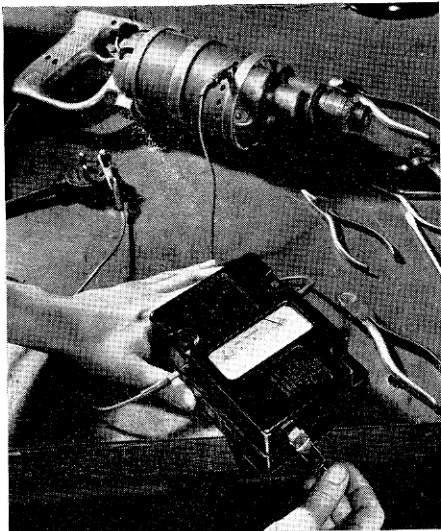

Figure 10
Testing the earth-continuity conductor of a portable electric tool



Figure 11
Making an insulation test at a switch-fuse

This book deals only with the insulation tests, and the requirements of the I.E.E. Regulations regarding insulation are set out below.

The methods of making continuity tests and of testing the polarity of switches are fully explained in a separate booklet No. 201 entitled "Continuity and Polarity Testing," obtainable on application from Evershed & Vignoles Ltd. A few notes are also given on page 29 of this pocket book.

Insulation tests. I.E.E. Regulations

These prescribe that electrical installations shall be tested on completion with a direct current pressure of not less than twice the working pressure, and that the insulation resistance of a completed installation shall not be less than 50 megohms divided by the number of outlets (points and switch positions) in the circuit, although no installation need have an insulation resistance greater than 1 megohm

$$\text{i.e. minimum insulation resistance} = \frac{50 \text{ megohms}}{\text{No. of outlets}}$$

For an incomplete installation, i.e. one without fittings, lamps, etc., the minimum insulation resistance should be not less than 100 megohms divided by the number of outlets.

Where p.v.c.-insulated cables are used, the equivalent values are $12\frac{1}{2}$ and 25 megohms divided by the number of outlets.

Need for periodical testing

It should be realised that the insulation resistance of the wiring in a house will not always remain the same although the materials may be of the best quality, but will depend a good deal upon the amount of moisture and dirt present on the fittings and accessories. Periodical tests of insulation resistance on installations are therefore very desirable, so that any deterioration due to moisture, dirt, atmospheric conditions or age may be detected and remedied.

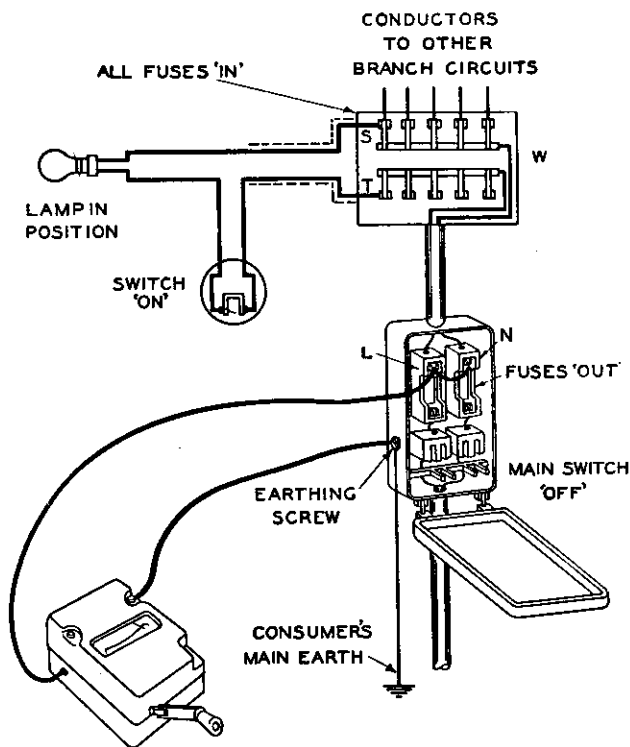

ALL SINGLE POLE SWITCHES 'ON'
 ALL LAMPS IN POSITION

Figure 12 Test to Earth on whole installation

How to make the insulation tests

(a) *Insulation tests to earth*

Disconnect the supply by opening the main switch and withdrawing the main fuses.

Insert all fuses at the distribution board (W, Figure 12).

Insert all lamps.

Close all single-pole switches.

On an incomplete installation, the conductors at each outlet (points and switch positions) must be joined together.

Join together the two contacts (L and N, Figure 12) on the installation side on the main switch, and connect these to one terminal of the Megger Insulation Tester.

Connect the other terminal of the Megger Tester to the conduit in which the wiring is run or, if lead-covered cable is used, to the lead sheathing. A second connection should also be made to the consumer's main earth (Figure 12). This second connection is, however, unnecessary if the continuity and earthing of the conduit has been previously tested, as described on page 29.

Turn the handle of the Megger Insulation Tester at about 160 r.p.m. and take a reading.

In circuits having 2-way corridor switches, two test readings should be taken, one switch in each pair being changed over before taking the second test, thus ensuring that both inter-switch wires (P and Q, Figure 15) are included in the test.

If the result of this test is considered satisfactory and is in accordance with the regulations previously mentioned, the installation may be pronounced as sound so far as resistance to earth is concerned.

If, however, the values obtained are not sufficiently high, withdraw all fuses at the distribution fuse board and test again. This test will only include the portion of the installation between the main switch and the busbars of the fuse board.

If the fault does not lie in this section, proceed to the distribution fuse board and test each branch circuit in turn (Figure 13) till the faulty circuit or circuits are discovered. These should be subjected to further tests as indicated in Figure 14 till the actual fault is located.

It might be as well to suggest at this stage, that every reading which is obtained should be written down, for it is a most annoying thing to test round a whole house and then find that one has forgotten the readings.

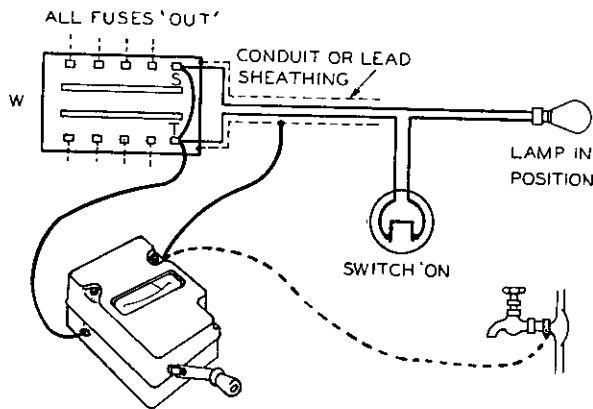
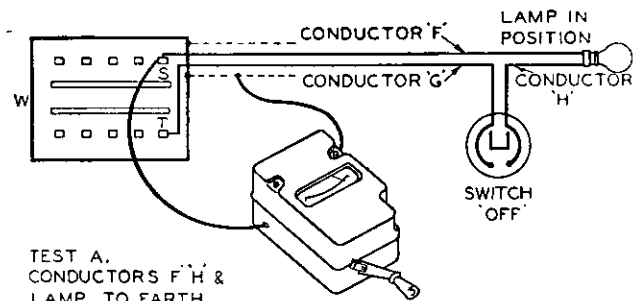

Figure 13

Test to earth on branch circuit

Connection to earth shown dotted to be used if the conductors are not enclosed in conduit or metal sheathing



TEST A.
CONDUCTORS 'F' 'H' &
LAMP TO EARTH

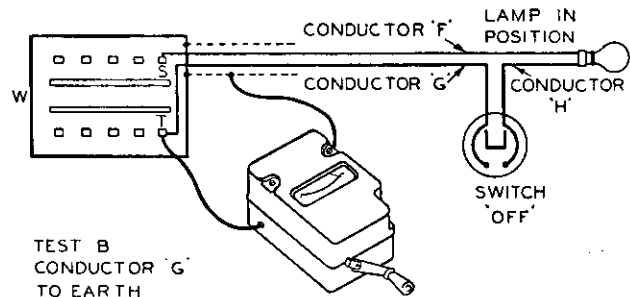

TEST B
CONDUCTOR 'G'
TO EARTH

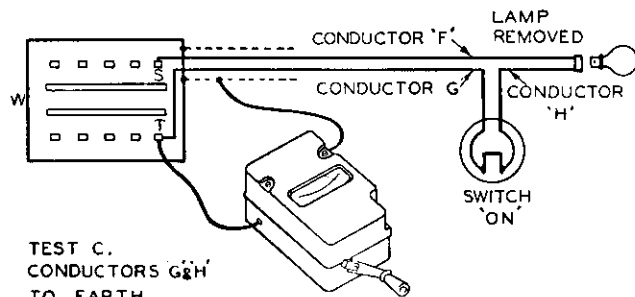

TEST C.
CONDUCTORS 'G' & 'H'
TO EARTH

Figure 14

Test to locate fault to earth on branch circuit

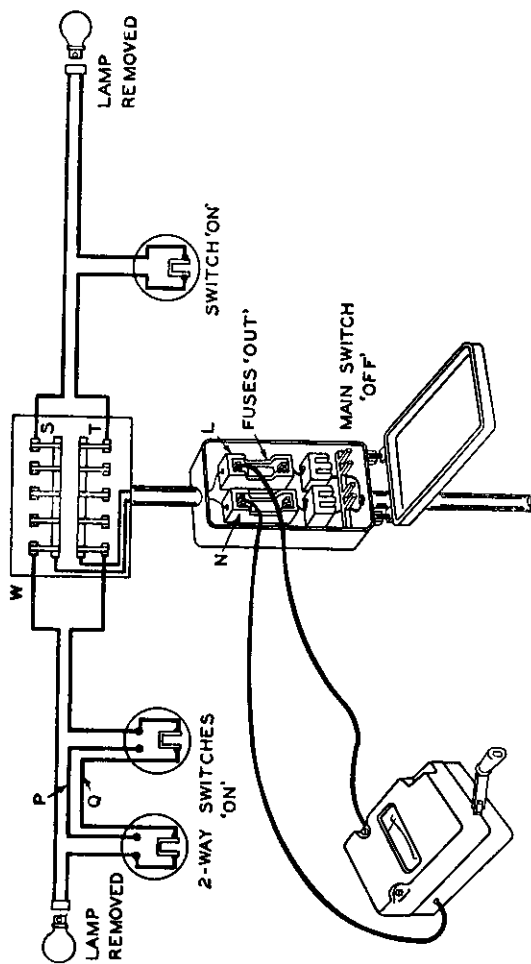

Figure 15
Tests between conductors on whole installation

(b) *Insulation tests between conductors*

Remove all lamps.

(The main switch must be open, all fuses inserted at the distribution board, and all single-pole switches in the closed or "ON" position* as in the previous test.)

Connect one terminal of the Megger Insulation Tester to fuse contact L (Figure 15), and the other to the contact N and make a test.

Two readings should be taken on an installation containing 2-way switches, one with both switches in one "ON" position (Figure 15) and the other with both switches in the alternative "ON" position; this will ensure that both inter-switch wires (P and Q, Figure 15) are included in the test.

If the result of the test between conductors is also satisfactory, no further insulation tests are necessary and the installation may be passed as sound.

If, however, the results of the tests are unsatisfactory, proceed to the distribution board, withdraw all fuses and test each branch circuit individually between conductors until the faulty circuit or circuits are located.

Having established the circuit upon which the fault lies, disconnect any component part of that circuit which it is convenient to remove. Disconnect, for instance, the flexible from ceiling roses and test again to see whether the removal of these small sections has cleared the fault.

It is as well to remember that although faults do occasionally occur in ordinary straight runs of cable, this is not the first place to look for trouble. It is much more frequently the case that faults, both between conductors and to earth, occur at switches, in ceiling roses, in lamp-holders, in junction boxes, etc.

*To test whether 2-way switches are in the "ON" position, insert the lamp they control. A Megger Insulation Tester connected between contacts L and N Figure 15 will show zero if the switches are in the "ON" position.

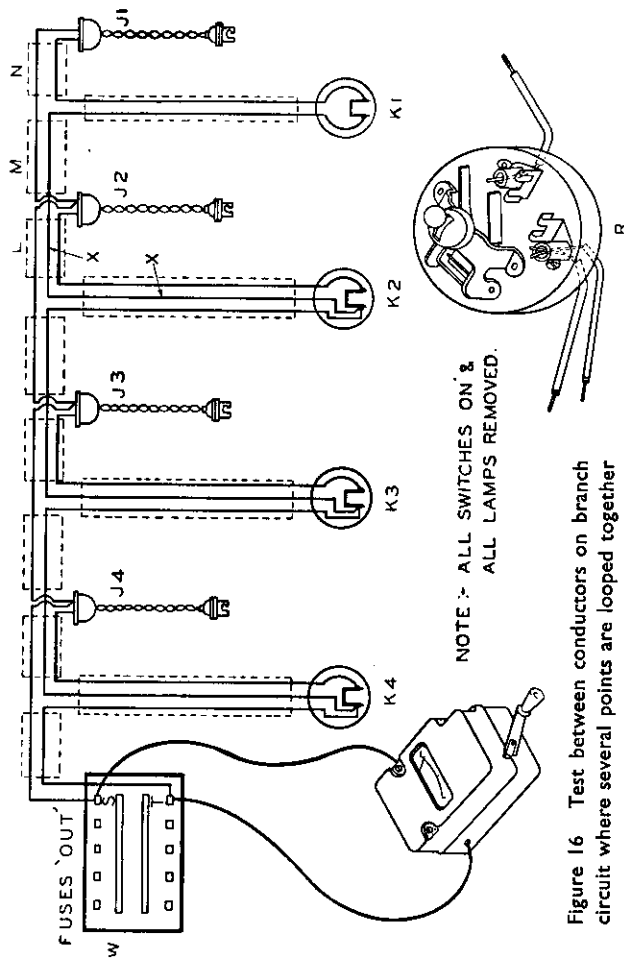

Figure 16 Test between conductors on branch circuit where several points are looped together

The actual steps to be taken in testing a circuit in which several points are looped together can perhaps be more clearly understood by reference to Figure 16.

Assume, for instance, that the branch circuit shown in Figure 16 is faulty. Proceed as follows:—

Open switch K1 and test again between S and T. If the fault has cleared it is apparent that it lies somewhere in the section of wiring between K1 and J1, i.e. in conduit N, ceiling rose J1 or the lamp flexible. If, however, the fault has not cleared, open switch K2 and repeat the test. If the fault now disappears it must have been in tube L, ceiling rose J2, or the corresponding lamp flexible.

If, after opening in turn each of the switches in the circuit, the fault still persists, it is evident that it does not lie in any of the wires between the switches and the lamps they control.

Start, therefore, the eliminating process again, this time not only opening the switch but disconnecting in turn at switches K2, K3, K4, etc., where the switch feed is looped out of each switch to the next one, at the point marked R on the enlarged view of the switch. This will eliminate in turn each switch feed, i.e. the wire which in the diagram is shown as the centre wire X, passing through the tube L. As soon as a disconnection in this way has resulted in a good test it may be concluded that the fault lies in the switch feed loop last removed.

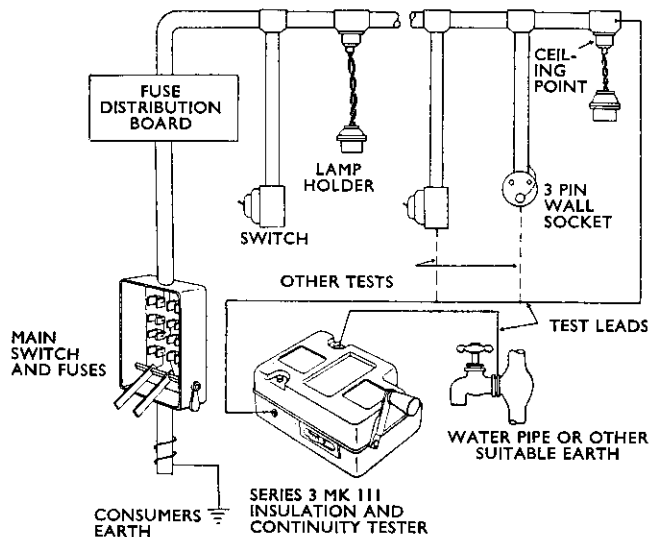

Figure 17 Testing the earth-continuity of an installation. Good contact must be made between test leads and conduit under test

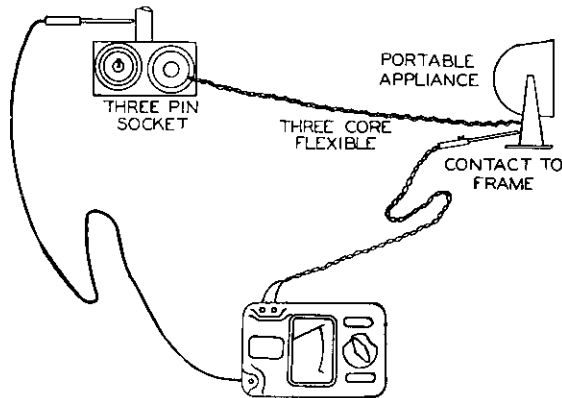

Figure 18 Earthing of portable apparatus. Simple method of tests if continuity of installations is sound

How to make the continuity tests

The normal insulation tester is unsuitable for these tests as the scale range is too high and the testing pressure excessive.

The instruments recommended for continuity testing are the Megger Circuit Testing Ohmmeter (page 35) and the Megger Insulation and Continuity Tester (page 34).

Continuity tests on installations must be made with the circuit wiring dead, the procedure being as follows:—

Before Testing

1. Open the mains switch and, as a precaution, remove the main fuses.
2. Connect one terminal of the testing instrument by a long test lead to a rising water main (as shown in Figure 17), or to the consumer's main earth.
3. This test lead should have an independent connection to the consumer's main earth so that the resistance of the actual earth connection is included in the test.
4. Connect the other terminal of the instrument by a short lead to switchboxes, ceiling roses, earth-sockets of 3 pin socket-outlets, to the conduit at 2 pin sockets, to the metallic frames of connected portable apparatus, to motor frames, etc.

The resistance actually measured includes that of the testing leads, which may be measured on the instrument and their value deducted.

The net values obtained should be in accordance with the appropriate I.E.E. Regulation No. 508(c).

If the resistance is excessive the cause must be sought by measurements made along the line of the continuity conductor until the joint causing the high resistance is located.

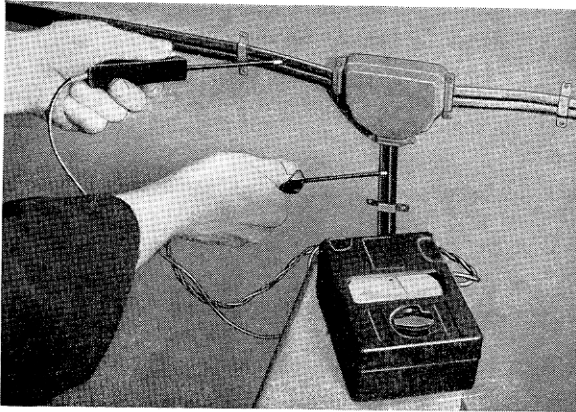

Figure 19 Measuring earth-continuity across a junction box

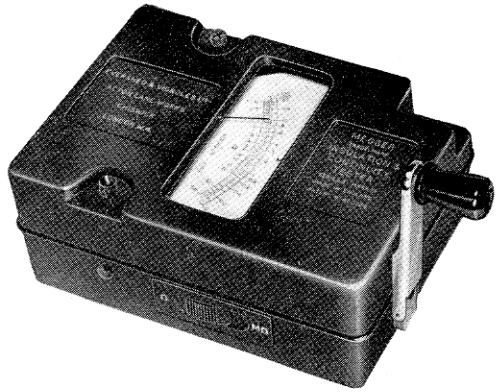

Figure 21 Megger Insulation and Continuity Tester, Series 3, Mk. III

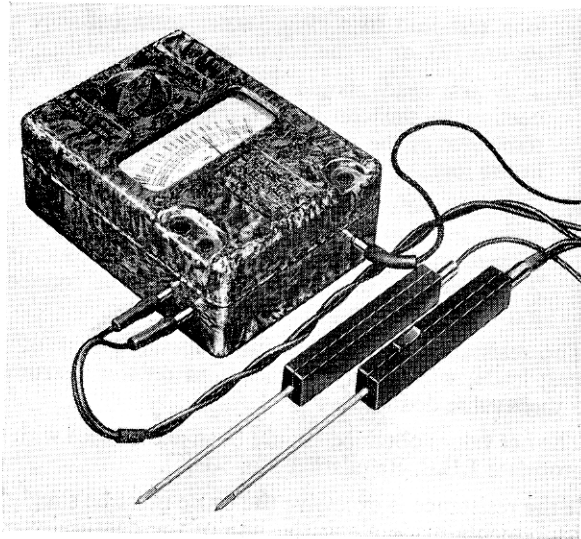

Figure 20 Megger Circuit Testing Ohmmeter

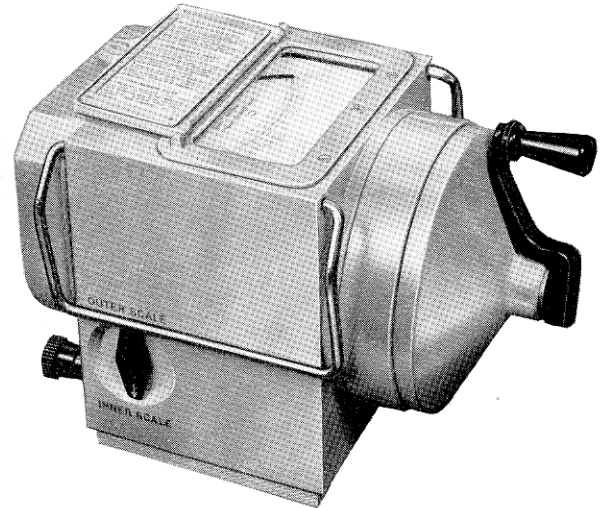

Figure 22 Megger Insulation and Continuity Tester, Series 2

MEGGER TESTERS

For insulation tests only

There are three series of instruments available for carrying out insulation tests only. These are illustrated in Figure 1.

1. Series 1 Tester

This instrument is recommended for testing high tension equipment, transformers, mains, etc. and apparatus having a high degree of insulation and considerable capacitance.

Ranges up to 50,000 megohms, 2,500 volts.

Size $14 \times 8 \times 8$ ins. Weight 30 lb.

2. Series 2 Tester

This is a convenient instrument for contractors and inspectors and is recommended for testing power circuits, motors, etc., operating on 500 volts, and for testing mains having moderate capacitance.

Ranges up to 2,000 megohms, 1,000 volts.

Sizes $5\frac{1}{2} \times 9\frac{1}{4} \times 6\frac{1}{4}$ ins. Weight 7 to 9 lb.

3. Series 3 Mk. III Tester

This pocket size instrument is suitable for testing house wiring, small motors, etc., operating on voltages not exceeding 250 volts, and for testing mains of moderate capacitance.

Ranges up to 100 megohms, 500 volts.

Size $5\frac{3}{4} \times 4 \times 2\frac{3}{4}$ ins. Weight $2\frac{3}{4}$ lb.

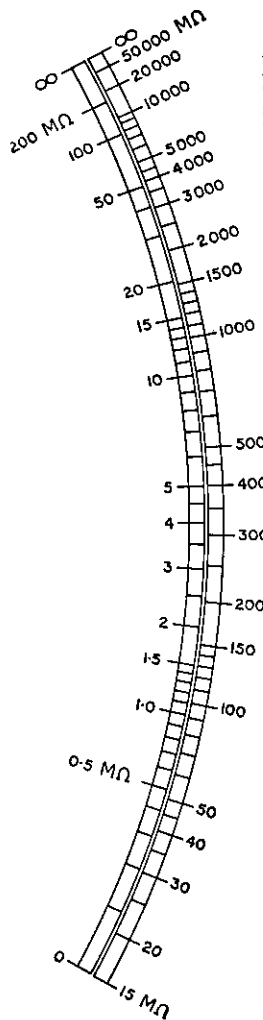

Figure 23

The word "Megger," which is derived from the words "megohm" and "tester," is the exclusive Trade Mark of Evershed & Vignoles Ltd., and is registered in all the principal countries of the world.

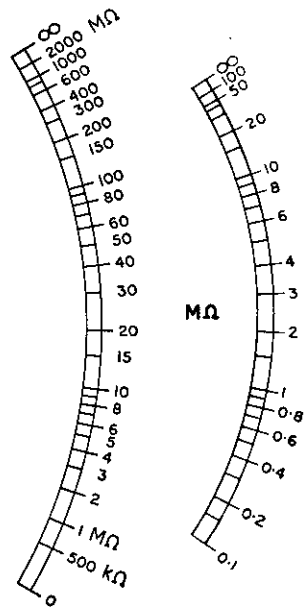

Figure 24 Figure 25

TYPICAL SCALES OF INSULATION TESTERS

Figure 23 Series 1 Tester (2,500 v.)

Figure 24 Series 2 Tester (1,000 v.)

Figure 25 Series 3 Tester (500 v.)

For insulation and continuity tests

The instruments for this dual purpose are the Megger Insulation and Continuity Testers, Series 2 or 3, illustrated on page 31. Though similar in appearance to the corresponding insulation testers, each instrument has a second scale graduated in ohms and a change-over switch enabling either scale to be selected at will. The continuity tests are made at low voltage.

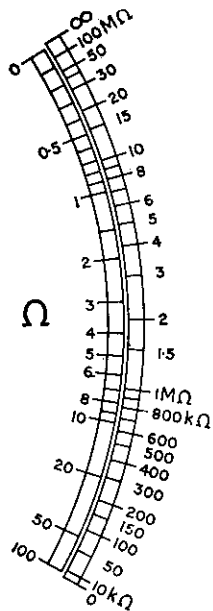

Figure 26
Series 2 (500v.)

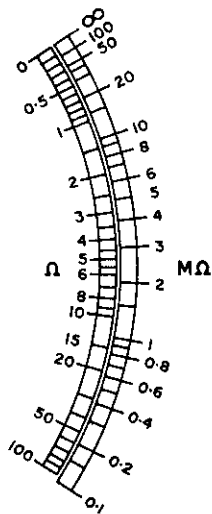

Figure 27
Series 3 (500v.)

TYPICAL SCALES OF INSULATION
AND CONTINUITY TESTERS

For continuity tests only

For this purpose the Megger Circuit Tester illustrated on page 30 is recommended. It consists of a direct reading ohmmeter with a self-contained dry battery, the whole being housed in a moulded plastic case measuring $5\frac{3}{8} \times 4 \times 2\frac{1}{4}$ ins. The ohmmeter movement being of the cross-coil type, the readings are independent of the battery voltage.

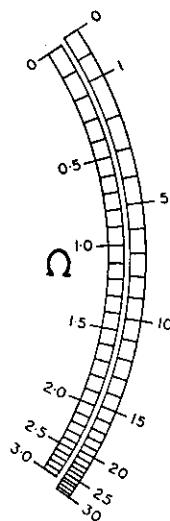

Figure 28

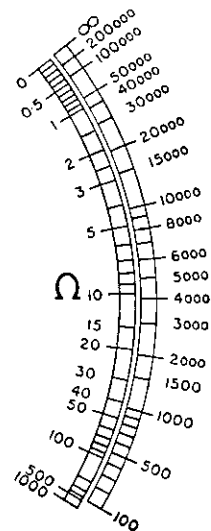

Figure 29

TYPICAL SCALES OF MEGGER
CIRCUIT TESTERS

Principle of operation

All the Megger Insulation Testing Sets described in this handbook consist of a hand-driven generator and a direct reading ohmmeter.*

The hand-driven Series 1 and 2 Testers have permanent magnet d.c. generators (Fig. 30) whereas the Series 3 Mark III Tester has an a.c. generator and a static rectifier (Fig. 31).

The ohmmeter movement contains no control spring, the latter being replaced by a control or pressure coil connected across the generator in series with a fixed control circuit resistance. The pointer will therefore only take up a definite position when the generator handle is turned.

The deflecting or current coil is also connected across the generator and, for insulation tests, it is in series with the resistance under test.

The instrument measures the ratio of the currents in the two coils, which will depend only on the value of the resistance under test, since variations in the pressure generated, due to varying handle speeds, affect both the coils in the same proportion. The instrument is therefore a true ohmmeter and is calibrated in megohms and thousands of ohms.

To guard against surface leakage, an instrument scaled up to 500 megohms or over is fitted with a guard terminal for connection as shown in Figure 30. Leakage current is thus returned directly to the generator without passing through the deflecting coil of the ohmmeter.

In the Megger Insulation and Continuity Testers, the change-over switch connects the deflecting coil *in parallel* with the resistance under test (see Fig. 32) instead of in series with it, and thus the scale reads in the opposite sense.

*Hand-and-motor driven pattern Series 1 Testers, and mains operated Series 1 and 2 Testers are also available.

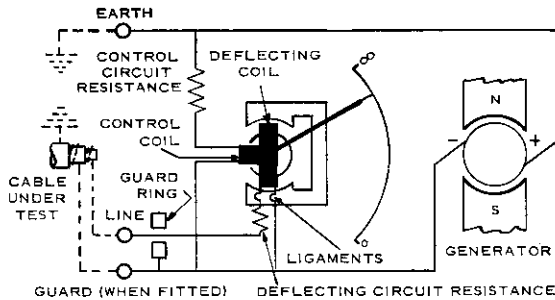

Figure 30 Series 2 instrument arranged for insulation test

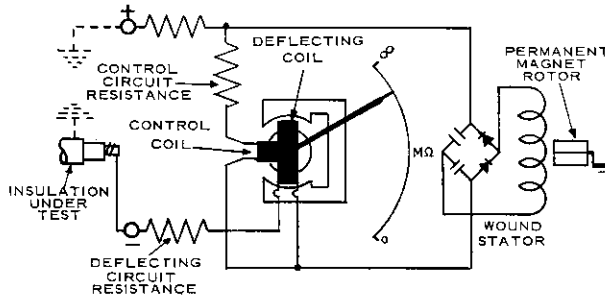

Figure 31 Series 3 instrument arranged for insulation test

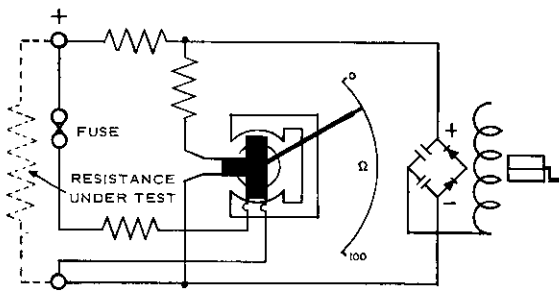

Figure 32 Series 3 instrument arranged for continuity test

Effect of capacitance

If a testing voltage is applied to any system of appreciable capacitance, a current will flow into the system until it is fully charged, even though the insulation is perfect. As a consequence, the indicating pointer of the Megger Insulation Tester will initially fall, subsequently rising to the correct insulation value.

If, moreover, the applied voltage varies, the generator of the insulation tester will alternately charge and discharge the capacitance, with the result that the pointer reading will be unsteady.

All the generators in Series 1 Testers and most of those in Series 2 instruments have centrifugally controlled clutches to give a steady voltage. However, these clutches are not necessary with the Series 3 Mark III Testers, the output voltage being kept steady by special voltage limiting features in the internal circuitry.

How to use Megger Testing Sets

1. Place the instrument so that the crank may be turned conveniently. Without making any connections, turn the crank and the pointer will move promptly over the scale and stand over the Infinity mark.

2. Connect suitable leads to the instrument terminals. Taking care that the other ends of the leads are not in contact with anything, turn the crank again, when the needle should once more stand over the Infinity mark; if it does not do so, there is a leak in the leads themselves.

3. Connect to the circuit to be tested, according to the instructions given in previous pages, turn the crank at about 160 revolutions per minute, and while turning the crank observe the position of the pointer on the scale. This shows the value of the insulation resistance under test.

4. If several successive readings show infinity resistance, touch the further ends of the test leads together while turning the handle slowly, to make sure that the leads are not disconnected or broken.

How to record results

As explained earlier in this book the comparison of one reading with another is of greater value in insulation testing than the absolute value obtained on test. Thus, if the record shows that for months the insulation resistance of a motor has been between 4 and 5 megohms and a test one day gives only 1 megohm, it is then desirable to make further tests at short intervals to ascertain if trouble is developing. On the other hand, if the results of the previous tests have been between 1 and 2 megohms, we need take no special action, as this insulation resistance is in most cases quite satisfactory.

In order to assist the users of Megger Insulation Testers, the publishers of this book have prepared a small log-book, and will, on request, send one free of charge to any user of Megger Insulation Testers.